

POWERSTAR PS19T / PS28T, SINGLE PHASE WATER HEATERS

ELECTRIC INSTANTANEOUS WATER HEATER INSTALLATION GUIDE AND OWNERS MANUAL



WARNING

READ THE GENERAL SAFETY SECTION BEGINNING ON THE INSIDE COVER AND THEN THIS ENTIRE MANUAL BEFORE INSTALLING OR OPERATING THIS WATER HEATER. IF YOU DON'T FOLLOW THE SAFETY RULES, THE UNIT WILL NOT OPERATE PROPERLY AND IT COULD CAUSE DEATH, SERIOUS BODILY INJURY AND/OR PROPERTY DAMAGE. READ ALSO THE ENCLOSED WARRANTY CARD. WARRANTY OF THIS WATER HEATER WILL DEPEND ON PROPER INSTALLATION AND OPERATION. THE WARRANTY SHALL BE VOID IF THE DESIGN HAS BEEN ALTERED IN ANY WAY WHATSOEVER. THE MANUFACTURER OF THIS HEATER WILL NOT BE LIABLE FOR ANY DAMAGES BECAUSE OF FAILURE TO COMPLY WITH THE INSTALLATION AND OPERATING INSTRUCTIONS OUTLINED ON THE FOLLOWING PAGES.

THE INSTALLATIONS AND SERVICE MUST BE PERFORMED BY A QUALIFIED INSTALLER, SERVICE AGENT OR ELECTRICIAN. THE INSTALLATION MUST CONFORM WITH THE INSTRUCTIONS IN THIS MANUAL; ELECTRIC COMPANY RULES; AND THE LOCAL CODES, OR IN THE ABSENCE OF LOCAL CODES, WITH THE LATEST EDITION OF THE NATIONAL ELECTRICAL CODE. UPON COMPLETION OF THE INSTALLATION, THESE INSTRUCTIONS SHOULD BE HANDED TO THE OWNER OF THE APPLIANCE FOR FUTURE REFERENCE.

IF YOU REQUIRE ANY HELP OR HAVE ANY QUESTIONS RELATING TO THE INSTALLATION OR PERFORMANCE OF THIS HEATER, PLEASE CALL OUR TECHNICAL SERVICE DEPARTMENT TOLL FREE : 1-800-642-3111.
PLEASE HAVE THE INFORMATION LISTED BELOW BEFORE CALLING :

SERIAL NO. _____ MODEL NO. PS T INSTALLATION DATE _____

GENERAL SAFETY

The PS19T and PS28T heaters are designed to take in cold water and heat it to temperatures suitable for normal domestic usage up to a maximum of 140 F(60 C). These models are not designed to be used as a sanitary booster which requires operating temperatures above 140 F(60 C) or for any recirculating type applications. To obtain optimum performance and energy savings, these units should be located as near as possible to the point of use.

The units is supplied with compression rings and nuts suitable for direct coupling to standard 1/2" (5/8" outside diameter) copper piping. There is no need for additional screwed fittings and under no circumstances use a blow torch on pipe while pipe is connected to the heater (serious damage to the electronic flow switch will result).

Also, ensure that the pipes are clear of installation debris before fitting the heater.

THE PS19T HEATER MUST HAVE TWO DEDICATED INDEPENDENT CIRCUITS AND THE PS28T MUST HAVE THREE DEDICATED INDEPENDENT CIRCUITS, USING CORRECTLY RATED WIRES AND CIRCUIT BREAKERS.

WARNING

FAILURE TO **GROUND** THE SYSTEM MAY RESULT IN DEATH OR SERIOUS INJURY.

WARNING

IMPROPER INSTALLATION, ADJUSTMENT, ALTERATION, SERVICE OR MAINTENANCE CAN CAUSE **DEATH, SERIOUS BODILY INJURY OR PROPERTY DAMAGE**. REFER TO THIS MANUAL FOR ASSISTANCE OR CONSULT THE LOCAL ELECTRIC UTILITY FOR FURTHER INFORMATION.

WARNING

WATER HEATERS EQUIPPED FOR ONE VOLTAGE ONLY: THIS WATER HEATER IS EQUIPPED FOR ONE VOLTAGE TYPE ONLY: CHECK THE RATING PLATE ON THE FRONT COVER OF UNIT FOR THE CORRECT VOLTAGE. DO NOT USE THIS WATER HEATER WITH ANY OTHER VOLTAGE OTHER THAN THE ONE SHOWN ON THE MODEL RATING PLATE. FAILURE TO USE THE CORRECT VOLTAGE CAN CAUSE PROBLEMS WHICH CAN RESULT IN DEATH, SERIOUS BODILY INJURY, OR PROPERTY DAMAGE. IF YOU HAVE ANY QUESTIONS OR DOUBTS CONSULT CEC OR YOUR ELECTRIC COMPANY.

WARNING

HAZARD OF ELECTRICAL SHOCK! BEFORE REMOVING THE COVER OR SERVICING THE WATER HEATER, MAKE SURE THE ELECTRICAL SUPPLY TO THE WATER HEATER IS TURNED "OFF". FAILURE TO DO THIS COULD RESULT IN **DEATH, SERIOUS BODILY INJURY, OR PROPERTY DAMAGE**.

MODEL PS19T



MINIMUM - 8" CLEARANCE ABOVE UNIT

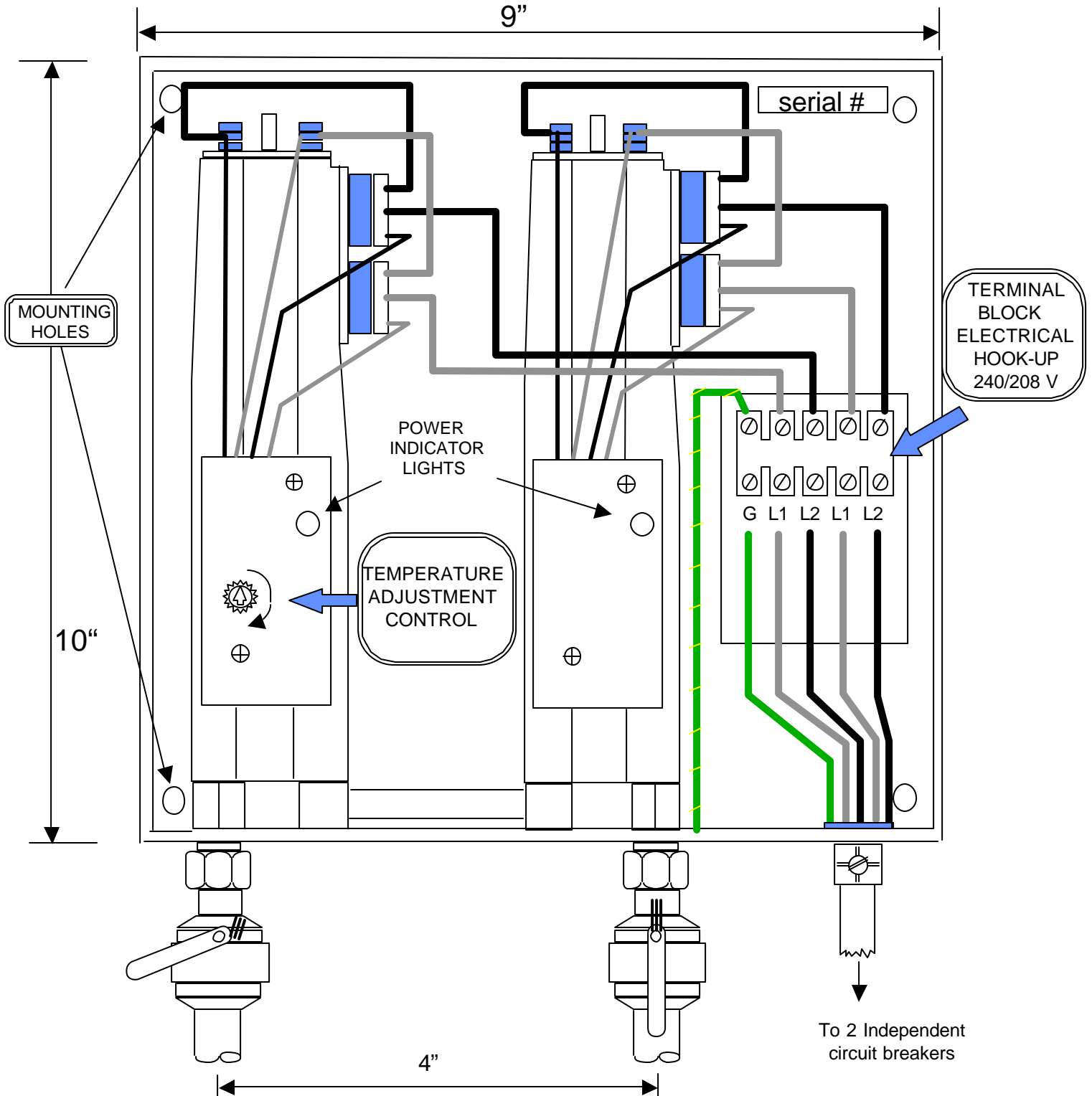

Outlet isolating valve-
ball valve (leave open
just enough to obtain
adequate flow of hot water)

Inlet isolating valve-
ball valve. (Always leave fully
open when unit is in service.)

MODEL PS28T



MINIMUM - 8" CLEARANCE ABOVE UNIT

12"

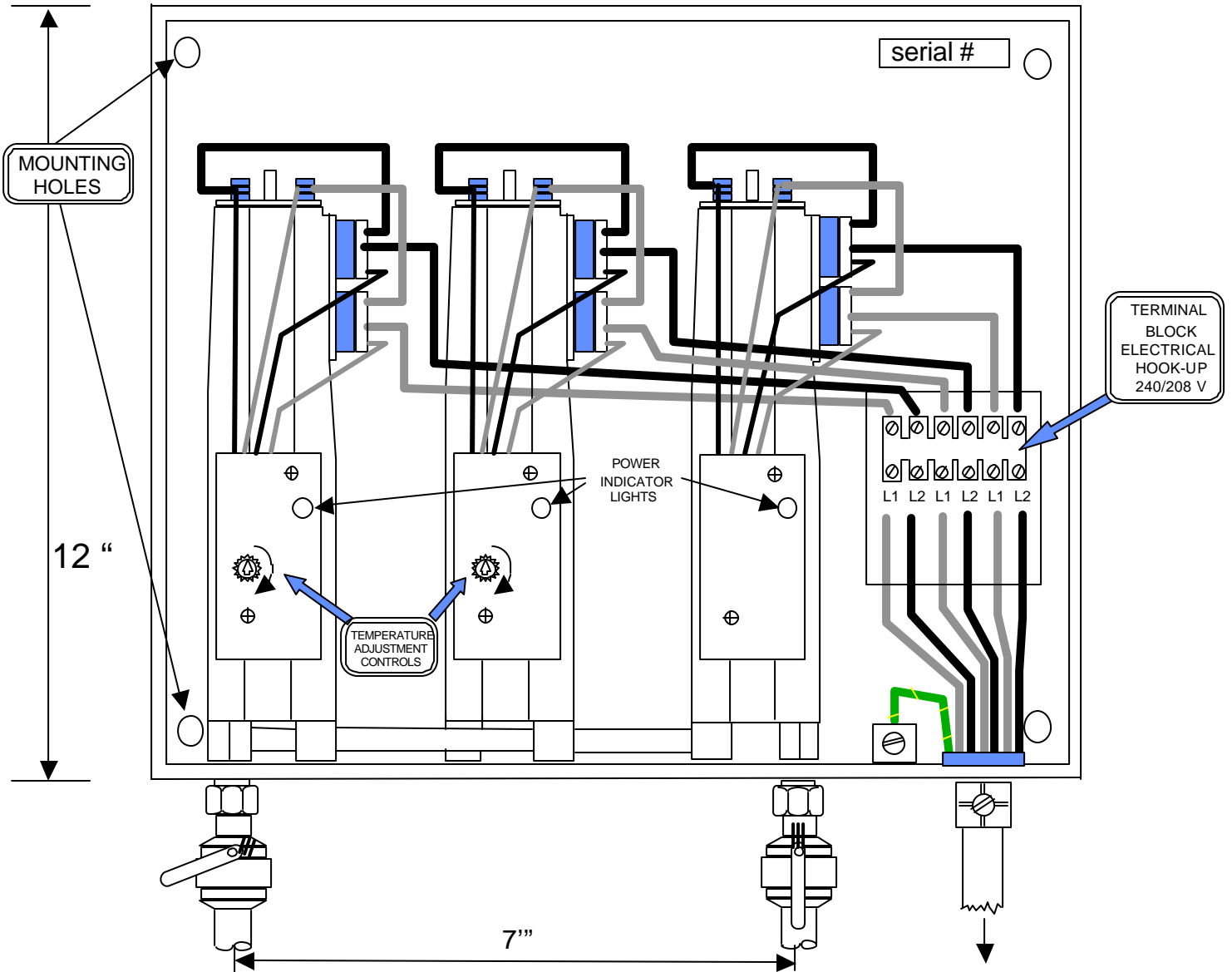

Outlet isolating valve-ball valve (leave open just enough to obtain adequate flow of hot water)

Inlet isolating valve-ball valve. (Always leave fully open when unit is in service.)

To 3 Independent circuit breakers

I. MOUNTING THE UNIT

- 1) The unit should be mounted as close to the point of use as possible. For example, directly beneath the sink is ideal.

Do not install the heater above a faucet or “point of use” because the siphoning effect may drain the heater which can cause premature element burn out.

- 2) This unit must only be mounted in a vertical position with the **water fittings located at the bottom of the unit**. Mounting other than in the vertical position **WILL** cause element burn out and cause permanent damage to the water heater.
- 3) The cold water inlet is on the right hand side and the hot water outlet is on the left hand side. Under **NO** circumstances can these be reversed.
- 4) Leave a minimum of 8” above the unit for easy replacement of the element.
- 5) The heater should be fixed to the wall using screws in the four mounting holes at each corner of the backplate.

NOTE: The heater should be installed below the level of all hot water outlets serviced by this heater.

NOTE: PRESSURE AND TEMPERATURE RELIEF VALVE

These units are not required by UL to have a Pressure and Temperature Relief Valve (PTRV). You should check with local codes to find out if one is required in your area.

If local codes require the use of a temperature and pressure relief valve it should be installed on the outlet hot water pipe before the outlet ball valve.

DISCLAIMER

As a condition of installing this product in the Commonwealth of Massachusetts a pressure relief valve shall be installed on the cold water side, by a licensed plumber MGL 142 Section 19 Approval number: P1-09-25

Showers and the whole house, cabin or condo

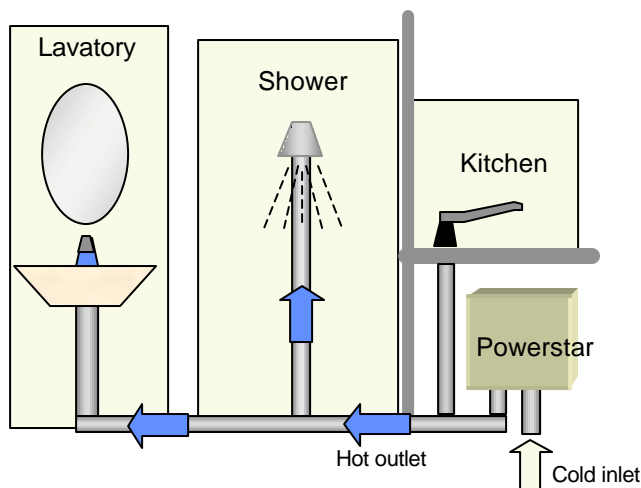

MODELS: **PS19T / PS28T**

Requirements:

About 0.85-2.5 GPM at showering temperature.
Best used when operating one outlet at a time.

II. PLUMBING HOOK-UP

- 1) The unit is supplied with compression fittings (Figure 1), USE THESE. DO NOT USE TAPERED THREADED PIPE FITTINGS AND DO NOT SOLDER TO THE INLET OR OUTLET. DO NOT USE ANY PIPE DOPE OR TEFLON TAPE WITH THESE COMPRESSION FITTINGS.
- 2) Take care to ensure that the pipes are correctly aligned with the inlet and outlet bosses in order to avoid excessive stress on the heater body molding.
NOTE: When soldering pipe joints remove heater from the wall. Serious damage can occur if any soldering is done while pipes are connected to the heater.

Run water through the supply pipe to remove all debris from the pipe before connecting the heater. Failure to do so could cause damage to the flow switch.

- 3) Install isolating valves (full flow ball valve type) on both inlet and outlet pipes. This allows unit to be isolated for maintenance purposes.
- 4) When all plumbing is complete, fully check the system for water leaks at all the plumbing connections. If a leak is present take corrective action. If the leak is at a compression fitting, slowly tighten the compression nut until it stops. Fully open both inlet and outlet BALL VALVES. Run all the hot water outlets fed by this heater one at a time, for a minute or two, until the water flow is continuous, free from “gulping” and from all visible air pockets.

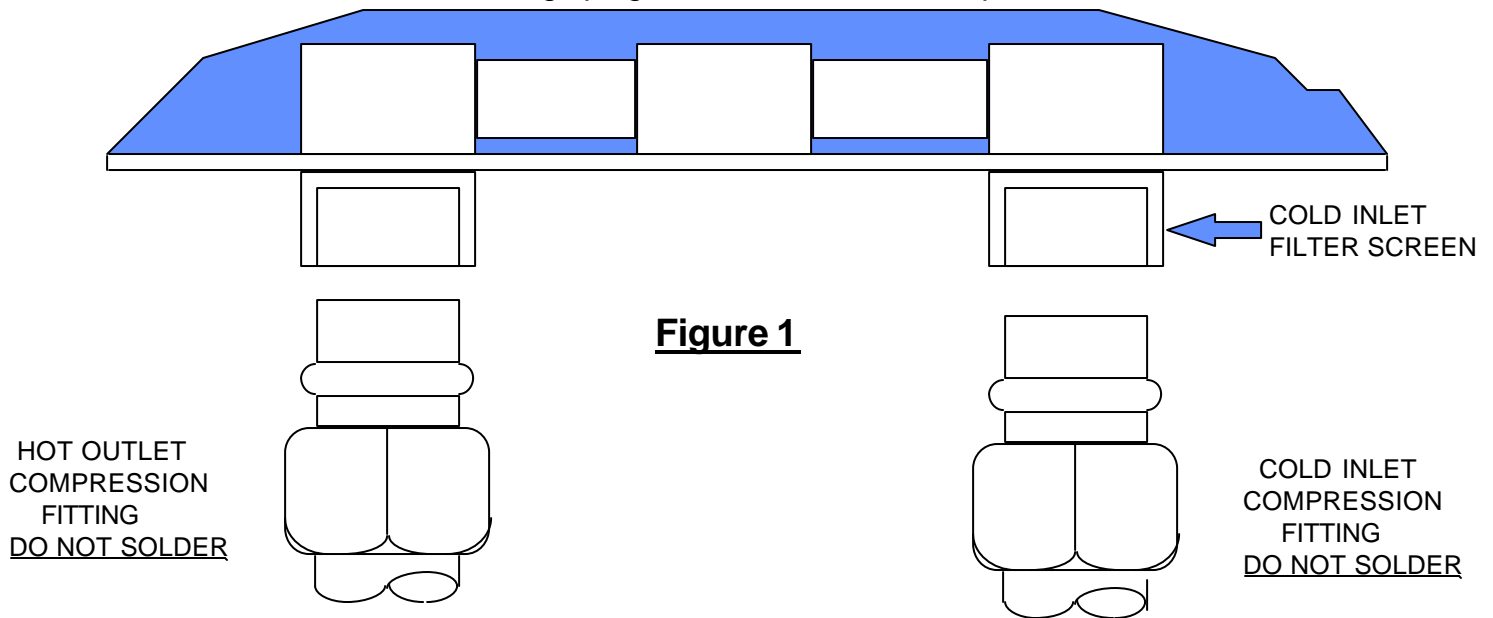

NOTE:
ALL MOUNTING AND PLUMBING MUST BE COMPLETE BEFORE YOU PROCEED WITH ELECTRICAL HOOK-UP.

TEST THE INSTALLATION FOR LEAKS BEFORE CONNECTING THE ELECTRICAL SUPPLY.

III. ELECTRICAL HOOK-UP

WARNING
BEFORE BEGINNING ANY WORK ON THE ELECTRICAL INSTALLATION, BE SURE THE SWITCH AT MAIN BREAKER PANEL IS "OFF" TO AVOID ANY DANGER OF ELECTRICAL SHOCK.

MODEL TYPE	OUTPUT / kW	VOLTAGE / V	AMPERAGE
PS19T	19	*240	2 X 40
PS28T	28	*240	3 X 40

* Units rated of 240 V can operate at 220 V or 208V with reduced output.
 The output will vary in accordance with the following ratios:

volts output ratio	208 volts	220 volts	240 volts
	.75	.84	1.0

This unit must have its own independent circuits. (For PS19T use 2 SETS of UL listed 2 conductor and ground core copper wire cable of the appropriate size protected by 2 separate and independent correctly rated Double Pole breakers. See Figure 2). (For PS28T use 3 SETS of UL listed 2 conductor and ground core copper wire cable of the appropriate size, **minimum 8GA wire size**, protected by 3 separate and independent correctly rated Double Pole breakers. See Figure 3). Applies for 208, 220 or 240 V. Wire entry into the unit must be made through the hole provided in the flange on the bottom.

The "live" wires should be connected to the slots in the terminal block marked L1 and L2. The ground lead must be connected to the slot marked GND. GROUND MUST BE BROUGHT TO THE "GROUND" AT THE CIRCUIT BREAKER PANEL.

Figure 2

2 Separate and independent correctly rated Double pole breakers (240/208 Volts)

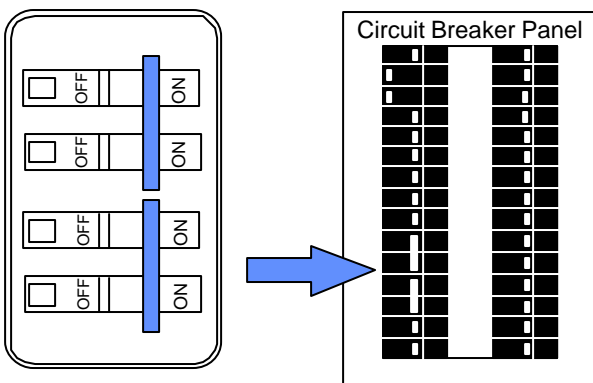
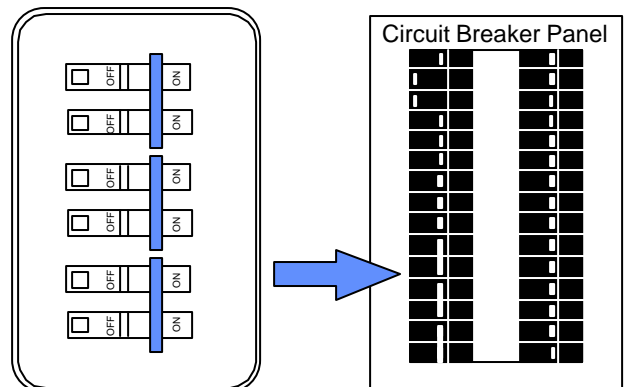

Figure 3

3 Separate and independent correctly rated Double pole breakers (240/208 Volts)



DANGER
FAILURE TO GROUND THE SYSTEM MAY RESULT IN DEATH OR SERIOUS INJURY.

IV COMMISSIONING YOUR HEATER

IMPORTANT

BEFORE SWITCHING "ON" THE POWER AT THE MAIN CIRCUIT BREAKER PANEL MAKE SURE THAT THE HOT WATER CIRCUIT IS FREE OF AIR POCKETS OR ELSE PREMATURE FAILURE OF THE ELEMENT WILL OCCUR. TO DO THIS OPEN ALL HOT WATER OUTLETS ONE AT A TIME FOR A MINUTE OR TWO UNTIL THE WATER FLOW IS CONTINUOUS AND FREE FROM "GULPING" AND FREE FROM VISIBLE AIR POCKETS.

- 1) Open fully both inlet and outlet valves at the heater.
- 2) Open fully the greatest hot water flowing outlet in the system. If the outlet is a "single lever" mixer type turn to the hottest position. Run for one minute to clear all the air from the system.
- 3) Slowly close OUTLET ball valve until the water flow from the faucet just starts to reduce.
NOTE: This process has two effects. One, any air in the system will be purged out. Two, the heater units will be pressurized at the supply pressure. This will prevent the elements burning when energized.
(Note: **Keep water flowing** while carrying out the procedures outlined below.)

OPERATING UNIT AND SETTING WATER TEMPERATURE

- a) Flow enough hot water to activate unit. The indicator light on the black flow control board should illuminate.
- b) Further increase the hot water flow and the indicator light on the clear thermostatic board to the left of the black board should illuminate. Note: This light should pulse On and Off at first and after about 20- 30 seconds it should stay fully on.
- c) Further increase the hot water flow and the indicator light on the next clear thermostatic board (PS28T model only) should illuminate. Note: This light should pulse On and Off at first and after about 20- 30 seconds it should stay fully on.
- d) Set (PS19T) thermostat to achieve the desired outlet temperature.
Set both (PS28T) thermostats to the same position to achieve the desired outlet temp.
- e) The thermostat is now set and the water temperature will always be the same when the indicator light is pulsing.
- f) Increasing water flow (above the flow rate at which the thermostatic control is no longer effective) will reduce the water temperature.

If a lower temperature is required for the PS19T, turn the temperature adjustment screw counter-clockwise about 1/8 of a turn (See pages 3 & 4 for adjustment location). Wait 15-20 seconds and check the temperature at the fixture. Repeat this process until the desired temperature has been achieved.

For PS28T model try to adjust the 2 temperature adjustment screws by about the same amount so that the lights pulse at the same rate. If you have reduced the temperature considerably from the 140 F setting, you could now open up the outlet ball valve slightly to achieve a higher rate of flow.

When the indicator light is on continuously, the unit is emitting full power. When it is pulsing, the unit is modulating the power to achieve the temperature set by means of the temperature adjustment screw.

In order to obtain good control at “single lever” mixer type faucets (single spout) the cold water supply to the faucet should be restricted to give approximately the same flow rate of cold water to the faucet as the hot water coming from your Powerstar heater. The simplest method of doing this is by partially closing the cold water valve under the sink.

MAXIMUM TEMPERATURE RISE CHART (°F)

Add your inlet water temperature to the degree rise to get the output temperature

MODEL	FLOW RATE (GAL. PER MIN.)						
	1	1.5	2	2.5	3	3.5	4
PS19T	92	74	54	43	----	----	----
PS28T	78*	88	75	61	54	55	----

*At a 1 gallon per minute flow rate, only 2 of 3 elements in the PS28T will initiate. The 3rd element initiates with a slightly greater flow rate.

TROUBLESHOOTING

SYMPTOM: NO HEAT INDICATOR LIGHT OFF

Solution 1) ELECTRIC SUPPLY IS OFF

Turn on the main circuit breaker. NOTE: If unit has been out of operation, first make sure that the hot water circuit is free of all air pockets or else premature failure of the element will occur.

Solution 2) INSUFFICIENT WATER FLOW

Insure that the minimum flow rate of 0.8 gpm to switch on your heater is met. 0.8 gpm is equivalent to filling a quart container in 18 seconds. Also check that the inlet filter screen is clear from any debris. This is located in the brass inlet boss (see Fig 1).

Solution 3) CROSSOVER IN PLUMBING

Cold water mixing with the hot outlet flow can back pressure the heater, test by isolating the Heater. Shut off the cold inlet supply to unit and open a hot water tap. There should be no flow.

Solution 4) WATER CONNECTIONS ARE REVERSED

Cold water inlet = right side, hot water outlet = left side.

Solution 5) ELEMENT BURNED OUT

TURN OFF THE MAIN BREAKER!

Using an ohmmeter test the resistance of the heating element across the two threaded termination rods on top of the element. The resistance reading should be under 10 ohms. If the resistance is much greater than this value, call CEC for a replacement element.

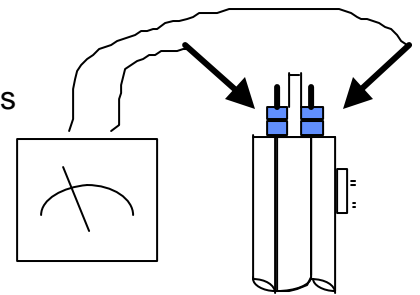

SYMPTOM: NO HEAT OR LOW TEMPERATURE WITH INDICATOR LIGHT ON

Solution 1) WATER FLOW TOO HIGH

Reduce the water flow by using an outlet ball valve. See page 9 for temperature rise at various flow rates.

Solution 2) INCORRECT POWER SUPPLY

Make sure that the unit is connected to the voltage supply specified on the rating label on the the front cover of the unit and no other.

Solution 3) ELEMENT BURNED OUT

TURN OFF THE MAIN BREAKER!

Repeat the steps from Solution 5 above.

Solution 4) THERMOSTAT ADJUSTMENT SCREW NOT TURNED UP

Turn thermostat adjustment screw(s) clockwise in small increments until the indicator light(s) remain on. Take care not to force the screw past its stop position.

PS19T REPLACEMENT PARTS DIAGRAM

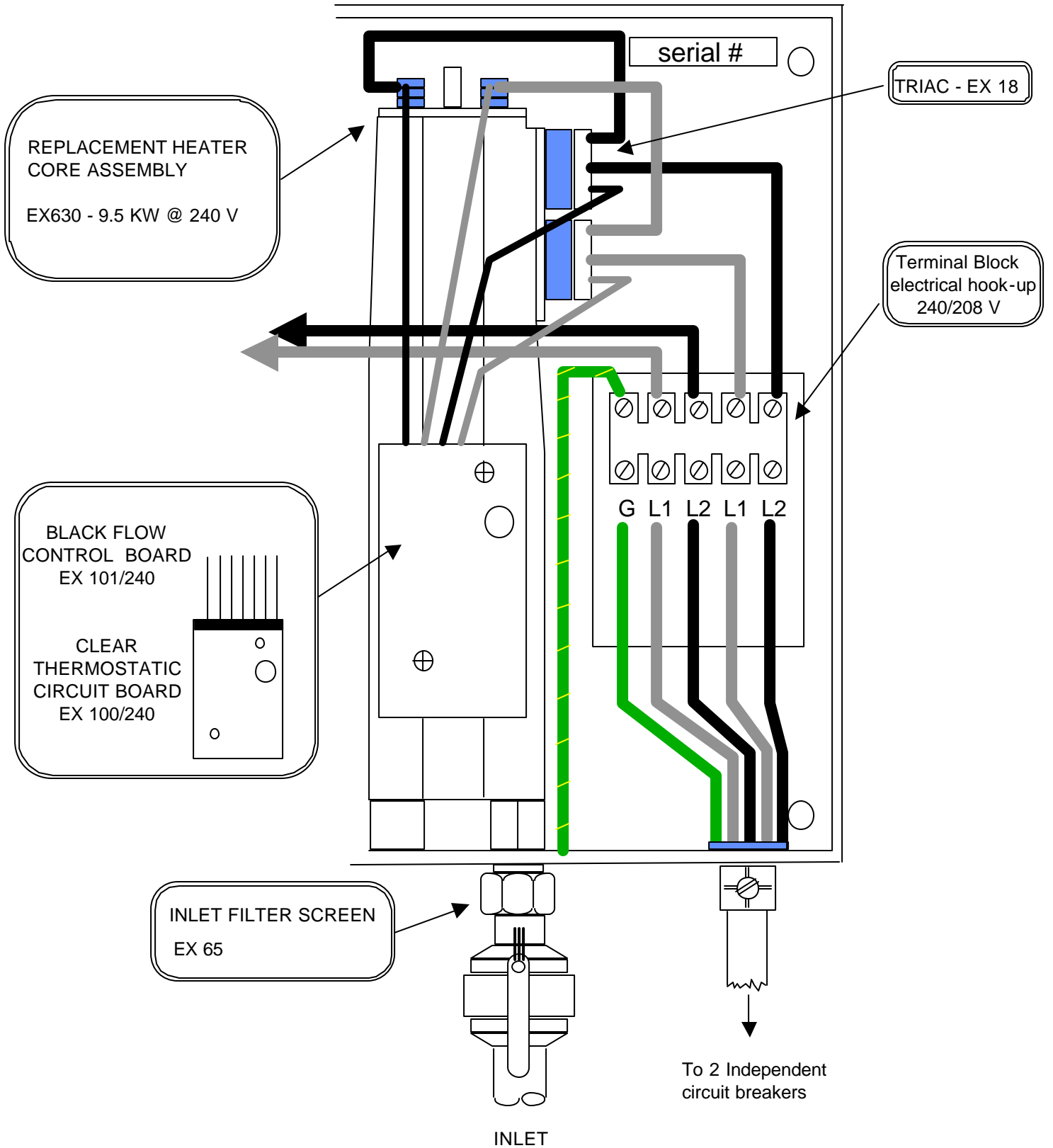

CEC, 340 Mad River Park, Waitsfield, VT 05673 800-642-3111

PS28T REPLACEMENT PARTS DIAGRAM

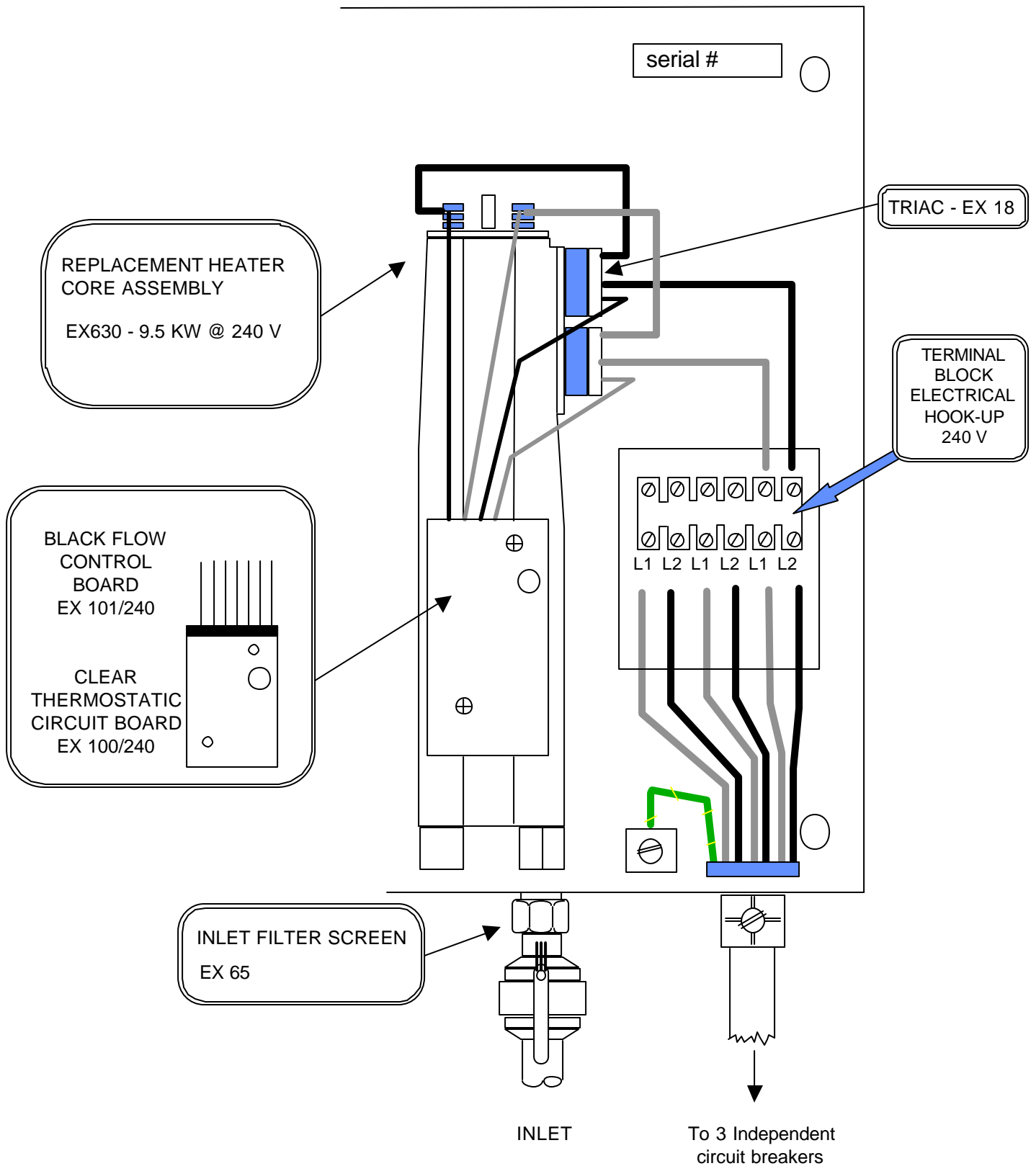

CEC, 340 Mad River Park, Waitsfield, VT 05673

800-642-3111

POWERSTAR • LIMITED 10 YEAR WARRANTY

COVERAGE

THE MANUFACTURER THROUGH ITS DISTRIBUTOR CONTROLLED ENERGY CORP., (hereinafter CEC) guarantees this water heater to the Owner (hereinafter "Owner") of the water heater at the original installation location against defects in material and workmanship for the periods specified below.

WARRANTY PERIOD

- 1. The Heat Modules** - If the original heat module(s) leaks within ten (10) years from the date of original installation of the water heater, because of a defect in material or workmanship, CEC will furnish to such Owner a new heater of the then prevailing comparable model.
- 2. Any Component Part Other than The Heat Modules** - If any other component part (other than the heat modules) proves to be defective in material or workmanship within one (1) year from the date of original installation of the water heater, CEC will furnish the Owner with a replacement of the defective part(s).
- 3. Verification of Date of Original Installation** - When Owner cannot verify or document the original date of installation, the warranty period begins on the date of manufacture marked on the serial number tag affixed to water heater.

EXCLUSIONS

- 1.** THIS LIMITED WARRANTY SHALL BE THE EXCLUSIVE WARRANTY MADE BY THE MANUFACTURER AND IS MADE IN LIEU OF ALL OTHER WARRANTIES, EXPRESSED OR IMPLIED (WHETHER WRITTEN OR ORAL), INCLUDING, BUT NOT LIMITED TO, WARRANTIES OF MERCHANTABILITY AND FITNESS FOR A PARTICULAR PURPOSE.
- 2.** Manufacturer shall not be liable for any incidental, consequential, special or contingent damages or expenses arising, directly or indirectly, from any defect in the water heater or the use of the water heater.
- 3.** Manufacturer shall not be liable for any water damage arising, directly or indirectly, from any defect in the water heater component part(s) or from its use.

- 4.** manufacturer shall not be liable under this warranty if:
 - a) The water heater or any of its component parts has been subject to misuse, alteration, neglect or accident, or
 - b) The water heater has not been installed in accordance with the applicable local plumbing and/or building code(s) and/or regulation(s), or
 - c) The water heater has not been installed in accordance with the printed manufacturer's instructions, or
 - d) The water heater is not continuously supplied with potable water.

5. The OWNER and not the Manufacturer or his representative shall be liable for and shall pay for all field charges for labor or other expenses incurred in the removal and/or repair of the product or any expense incurred by the owner in order to repair the product.

SOME STATES DO NOT ALLOW THE EXCLUSION OR LIMITATION OF INCIDENTAL OR CONSEQUENTIAL DAMAGES, SO THE ABOVE LIMITATION OR EXCLUSION MAY NOT APPLY TO YOU. THIS WARRANTY GIVES YOU SPECIFIC LEGAL RIGHTS AND YOU MAY ALSO HAVE OTHER RIGHTS WHICH MAY VARY FROM STATE TO STATE.

NOTE: A water heater should be installed in such a manner that if it should leak, the resulting flow of water will not cause damage to the area in which it is installed.

HOW THE OWNER CAN SECURE SERVICE OR MAKE A CLAIM

- 1.** Owner should contact the dealer who sold the water heater covered by this warranty or
- 2.** Owner should submit the warranty claim directly to CEC at the address listed below, and they will arrange for the handling of the claim
- 3.** Whenever any inquiry or service request is made, be sure to include the water heater model number the date of manufacture, date of installation, Dealer's name and the watts and voltage.
- 4.** When returning the water heater or component part(s), they must be individually tagged and identified with the Returned Goods Authorization # issued by CEC and shipped prepaid to CEC.